

Rudder Port Bearings - With Seals



Australasia/Pacific

Contact Dave: +61 402 062 449

info@tidesmarine.com.au

www.tidesmarine.com.au

Type E

PRODUCT OVERVIEW



The Tides Marine RPB Type E unit is designed to be installed in rudder tubes which have been laminated or welded into a vessel's hull.

The unit consists of a one-piece UHMW housing with a nitrile lip seal. It eliminates metal-to-metal contact and the associated problems of abrasion, electrolysis and corrosion. It is 100% watertight and eliminates chatter and vibration, resulting in a quieter, smoother operation.

Rudder Port Bearings - With Seals

Type E

BEFORE ORDERING

Tides Marine makes Type E assemblies based upon a combination of rudder stock diameter (.000") and the rudder tube I.D. When placing your order, please provide both of these dimensions.

If space is available, the red "hat" installation tool can be inverted and rested on top of the rudder bearing to help protect the lip seal from debris.

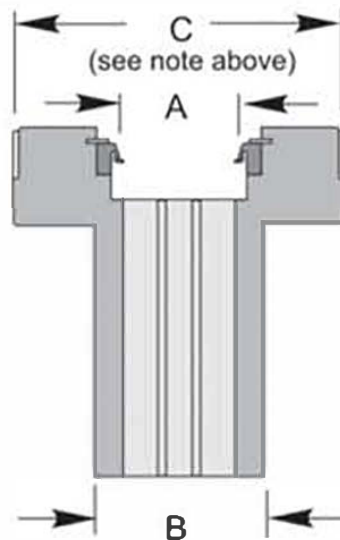
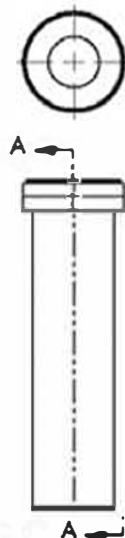
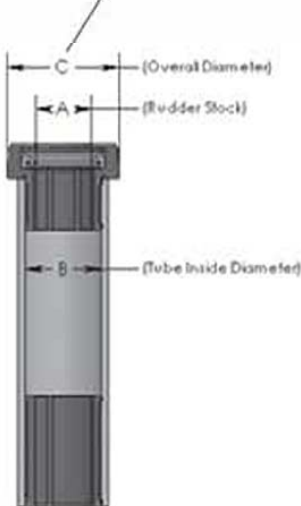
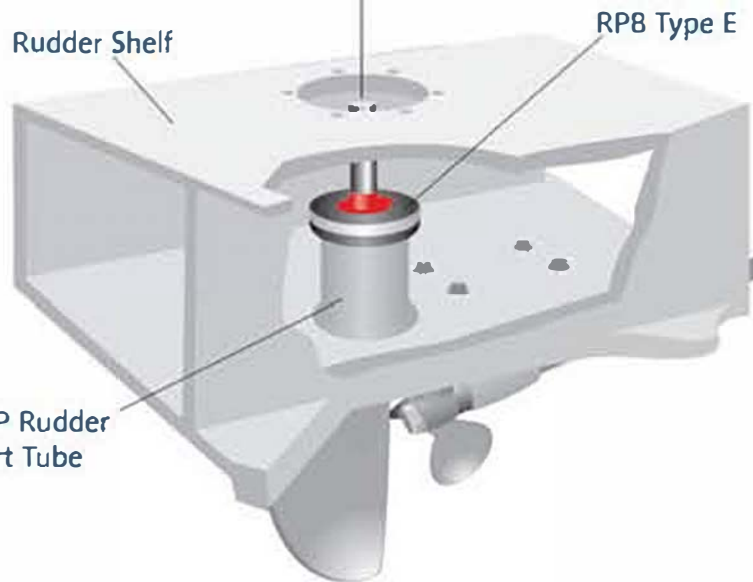
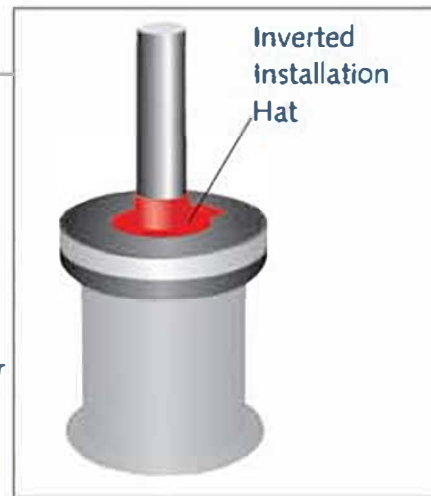

Design Note:
Diameter "C" must be at least equal to the rudder stock diameter plus 1 1/2".
Diameter "B" must be at least equal to the rudder stock diameter plus 3/4".