

Rudder Port Bearings - No Seals



Australasia/Pacific

Contact Dave: +61 402 062 449

info@tidesmarine.com.au

www.tidesmarine.com.au

Types G/H

PRODUCT OVERVIEW



Type G



Type H

Tides Marine RPB Type G and RPB Type H units are designed to be installed in rudder tubes which have been laminated or welded into a vessel's hull. These units are simple bearings and do not provide a sealing function. Type G units have a flange and Type H units do not. They may be used on power boats and sailboats. To improve the strength of the bond between these units and the rudder tube, external bonding grooves are machined into the OD of each part.

The units consist of a one-piece UHMW housing which has fluted, self-cleaning grooves running axially along the ID of each part. They eliminate metal-to-metal contact and the associated problems of abrasion, electrolysis and corrosion. They eliminate chatter and vibration resulting in quieter, smoother operation.

Rudder Port Bearings - No Seals

Types G/H

PRODUCT OVERVIEW

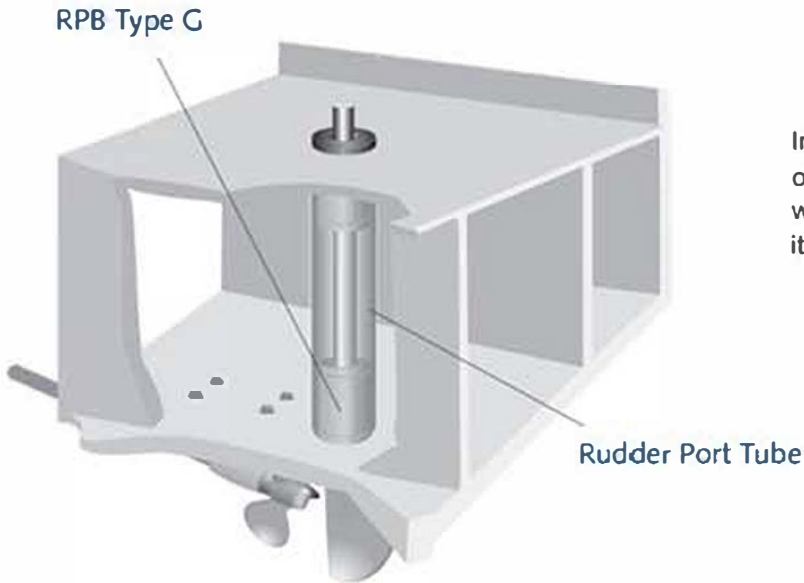

Inserting a Type G bearing into the bottom of a rudder tube also provides an impact/wear surface for the top of the rudder, should it ever rise to abut the bottom of the boat.

The Type H bearings slide neatly into the rudder tube and remain flush with the bottom of the rudder tube.

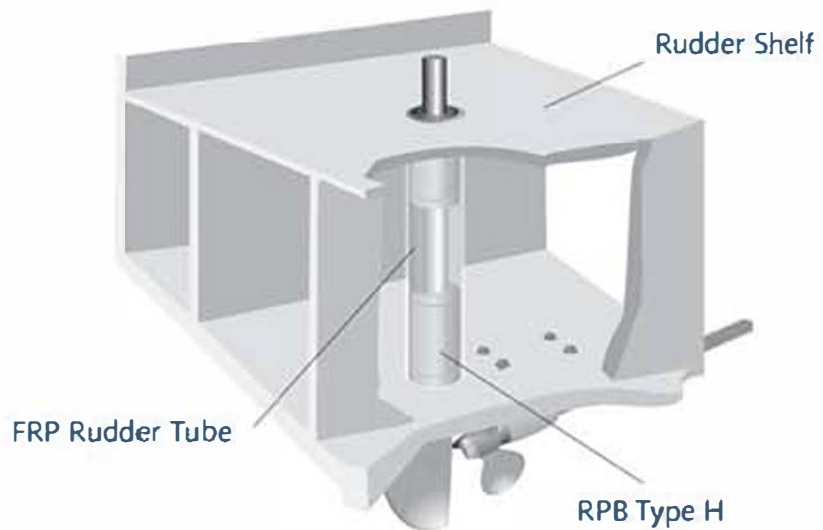

Rudder Port Bearings - No Seals

Types G/H

BEFORE ORDERING

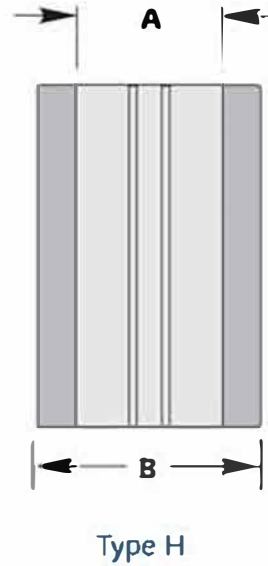
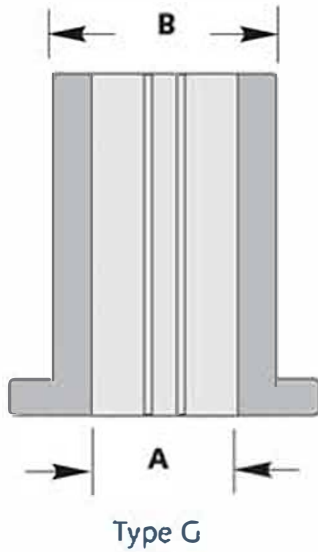

Tides Marine makes Type G and Type H assemblies based upon a combination of the rudder stock diameter (.000") and the rudder tube I.D. When placing your order, please provide both of these dimensions and specify the model (G - with flange or H - no flange). Tides will assign your part number based upon this information.